

## OWNER'S MANUAL SH-183 & SH-184 GAS BARBECUE

USE ONLY THE HOSE AND HOSE CONNECTOR PROVIDED!

If a replacement is necessary, please contact either our Customer Service Department or your local dealer.

The use of unauthorised parts can create unsafe conditions and environment.

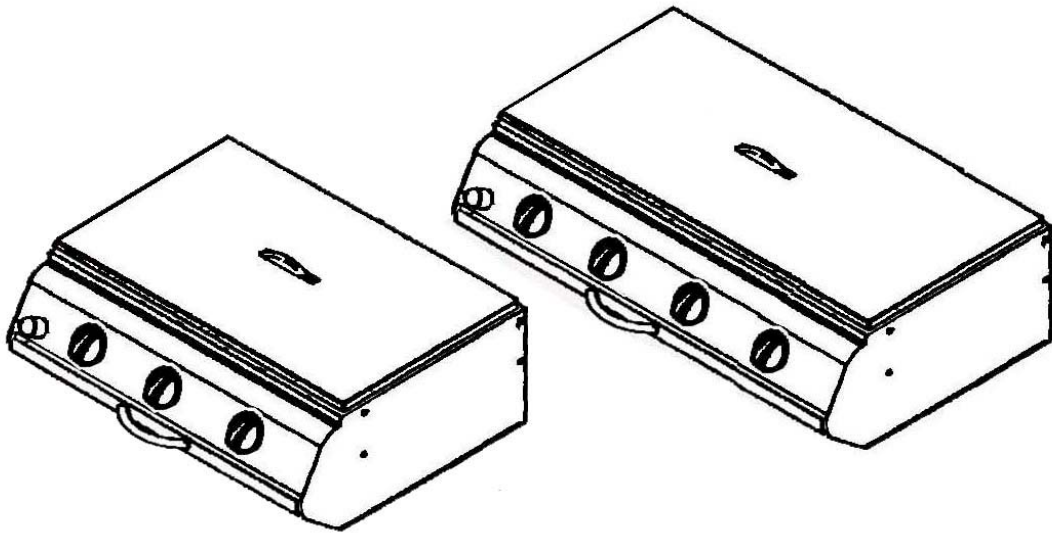

Before you begin assembling and using your new BBQ grills we recommend that you read through owner's use and care manual to avoid serious body injury or property damage.

**Note to Assembler/Installer:** Leave these instructions with the consumer.

## **Important Safety instructions**

The barbecue is safe and easy to use. The following rules must be followed.

1. Ensure that the unit has been assembled correctly according to the instructions.
2. Never loosen, or allow the gas connection to become loose. Should this happen, immediately ensure that the gas is turned off, and then re-check the security of the connection.
3. **The appliance shall be kept away from flammable materials.** There should be no combustible materials less than 250mm from the sides of the barbecue and less than 1500mm above the cooking surface of the barbecue.
4. Read the Users instruction, and instructions written on the grill, refer to them whenever necessary.
5. **Never leave the grill unattended while grilling.**
6. In the event of a gas leak, turn off gas supply at the cylinder.
7. **Keep children well clear while grill is in use and after use until it has cooled.**
8. Keep grill area clear of combustible materials and/or liquids.
9. Never obstruct free flow of air to the rear of the grill, or alter/adapt the barbecue to suit any other situation.
10. Follow your local municipality or your country's rules regarding laws and bylaws for proper and safe installations.
11. Never change the pressure of the regulator or the air valve settings of the burner.
12. Every time the cylinder is reconnected do a leak test.
13. **Protective gloves should be worn if hot parts or utensils are to be handled.**

**Technical Data:**

The barbecue are I 3+(28-30/37), I 3B/P(30) and I 3B/P(50) appliances, designed to operate on Butane at 28/30mbar, Propane 37mbar and B/P 30/50mbar. Gas consumption, pressures and injectors size are shown below:

**SH-183**

	<b>Injector Orifice</b>	<b>Heat Output</b>	<b>Gas Consumption</b>
I 3+(28-30/37), I 3B/P(30)	1.15	16kw	1151g/h
I 3B/P (50)	0.95	16kw	1151g/h

**SH-184**

	<b>Injector Orifice</b>	<b>Heat Output</b>	<b>Gas Consumption</b>
I 3+(28-30/37), I 3B/P(30)	1.15	21kw	1510g/h
I 3B/P (50)	0.95	21kw	1510g/h

Ignition: Push-button ignition system.

**IMPORTANT:**

Read the following instructions carefully and be sure your barbecue is properly installed, assembled and cared for. Failure to follow these instructions may result in serious bodily injury and/or property damage.

If you have any questions concerning assembly or operation, consult your dealer or LPG Gas Company.

Never cook with the side burner shelf in the closed position.

Never fit the cylinder under the barbecue in the housing always place the cylinder under the side shelf at the end of the appliance or at the rear of the appliance. The cylinder should be sited as far away from the appliance as possible without straining the hose.

Note: For cooking longer periods of 30 minutes we recommend the use of Propane Gas.

**Gas Regulator**

A gas regulator conforming to the national standard must be fitted to the gas cylinder to provide the appropriate gas pressure.

Do not use this appliance with an adjustable regulator.

**NOTE FOR CONSUMER: Retain for future Reference**

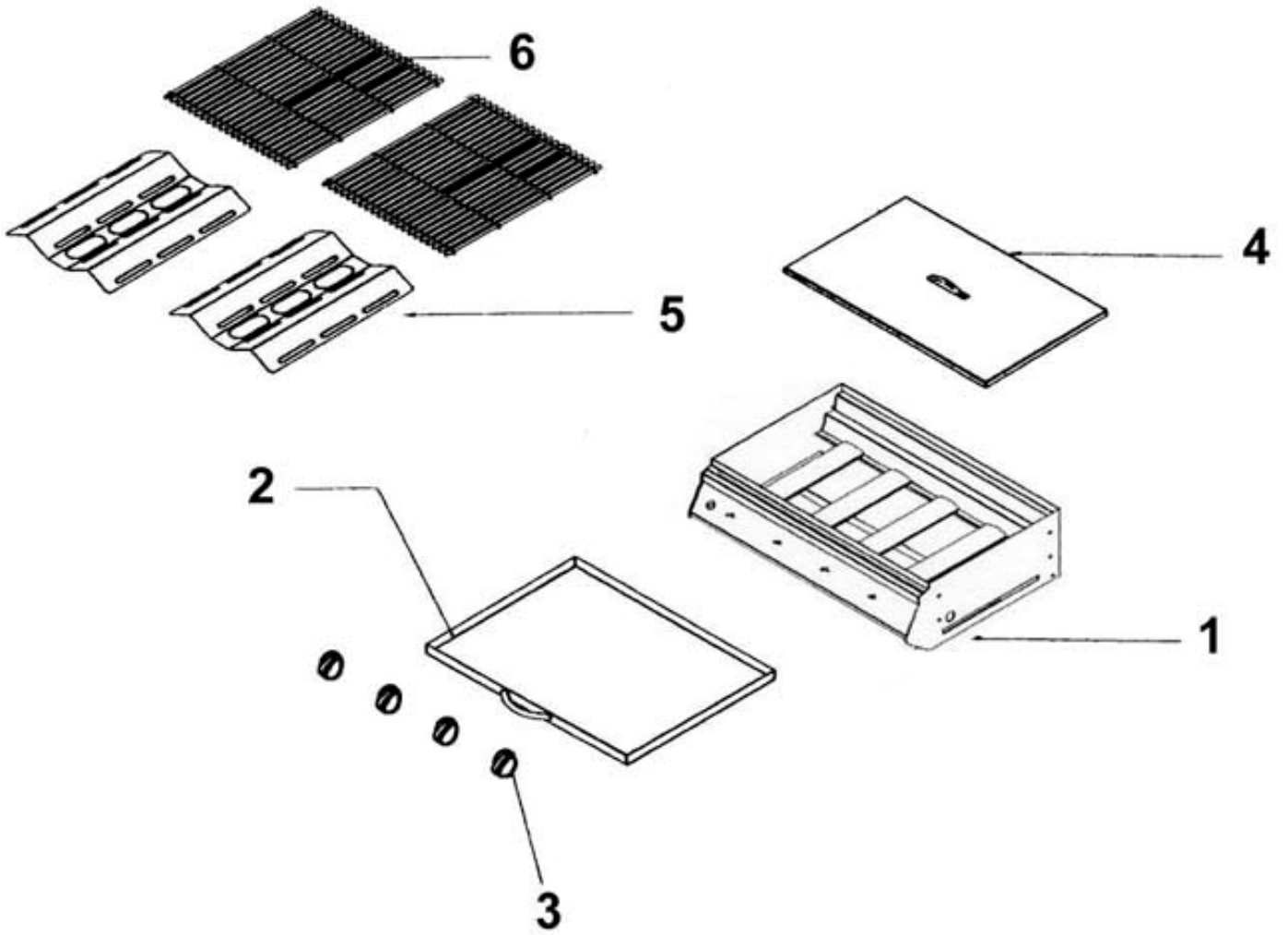

**SH-184**

No.	Parts	QTY
1	Grill body	1
2	Grease tray	1
3	Control knob	4
4	Lid	1
5	Flame tamer	2
6	Cooking grid	2

**SH-183**

No.	Parts	QTY
1	Grill body	1
2	Grease tray	1
3	Control knob	3
4	Lid	1
5	Flame tamer	1
6	Cooking grid	2

**NOTE: regulator with hose**  
**Because of a variety of fittings, this item is not included.**  
**Available from dealer**

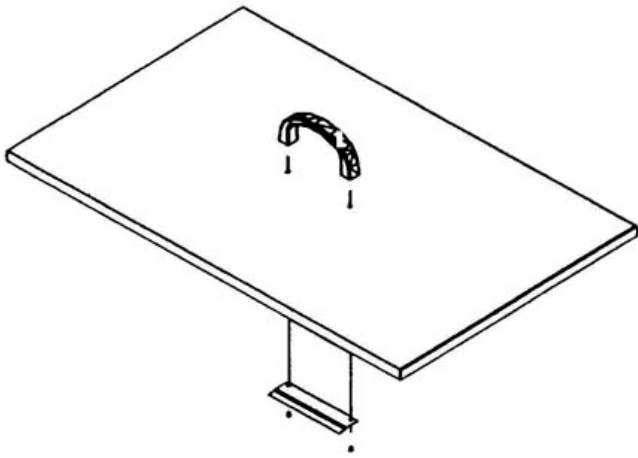

**Step 1**

**Attach handle of the lid, as shown.**

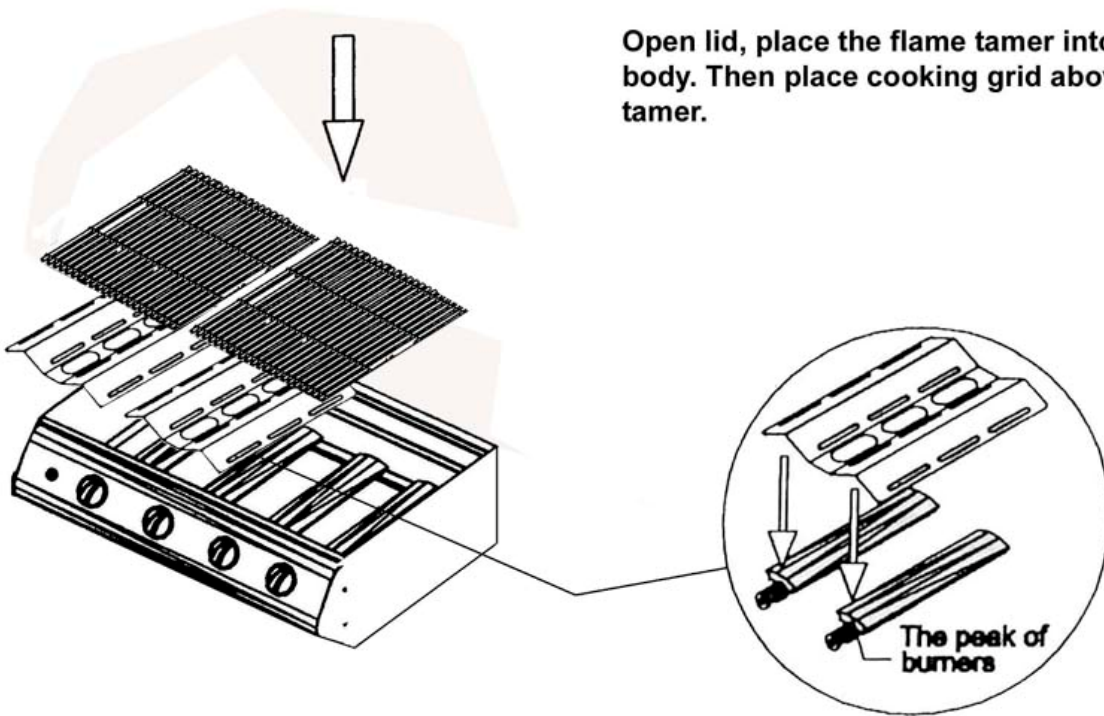
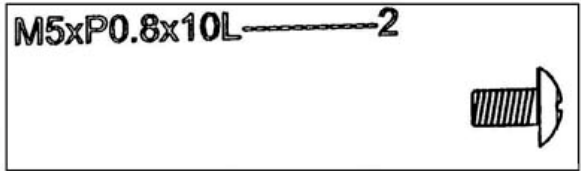

**Step 2**

**Open lid, place the flame tamer into the grill body. Then place cooking grid above flame tamer.**

Dear User,  
When you have assembled your barbecue, please pull all screws tight after 2 – 3 days, especially the screws holding the frame (but do not over tighten them). Only then can the stability of your barbecue be assured. The materials used tend to loosen again after the first tightening and connections could thus become unsteady.

### **3. Always Be Aware**

The grill must only be used outdoors and placed firmly on a solid, even and non-combustible surface, shielded from wind. There should be no combustible materials less than 250mm from the sides of the barbecue and less than 1500mm above the cooking surface of the barbecue.

**IMPORTANT: Keep children away from the barbecue during use, and until it has cooled down after use.**

**IMPORTANT: Any modification of this unit can be dangerous. Do not place the grill near entrances, doorways or in thoroughfares. Do not use charcoal, briquettes or lighter fluid in any gas BBQ. Shield the Gas container from direct sunlight. BBQ units should never be placed in a fully enclosed patio area without a chimney or non-flammable exhaust hood, with an efficient exhaust fan. Never move the grill while it is hot or in operation.**

**THE GAS CONTAINER MUST BE PLACED UPRIGHT BY THE SIDE OF THE GRILL**

### **4. To connect the gas bottle to the unit:**

- ◆ Attach the hose to the manifold inlet nipple and tighten hose clip. Ensure that all connecting threads and surfaces are undamaged, clean and free from oil dirt. When fitting the hose make sure that it is free from twisting, kinks or sharp bends.
- ◆ Protect the hose from dripping grease and do not allow it to touch any hot surface or sharp edges.
- ◆ Attach the regulator to the gas cylinder. Refer to the instructions supplied with the regulator for details regarding fitting.
- ◆ Test for gas leaks. Do a leak test each time the cylinder is installed, whether or not it has been filled. Check all other joints at least once a year.
- ◆ If the hose shows deterioration or damage, leak test the entire outer surface while under pressure. Replace at first sign of leak or age cracking.
- ◆ Remember to turn the cylinder valve OFF before removing the hose.

## Testing for Leaks

- ◆ Ensure burner knobs are OFF and open the cylinder valve.
- ◆ Use a solution of half detergent and half water for leak testing. Brush solution on each connection and check for bubbles.
- ◆ If a leak is present, tighten the loose joint.
- ◆ If leak persists contact an authorized agent.

### **5. Instructions for first users**

**Before using the new grill for the first time, it is advisable to follow this procedure:**

**Before cooking for the first time, operate the barbecue for about 15 minutes with the lid opened and the gas turned on HIGH. This will “heat clean” the internal parts and dissipate odour from the painted finish. This will season the grill and prepare it for your first barbecue.**

**Ensure that the cooking surfaces are clean and dry. Coat the cooking surfaces with cooking oil, light all burners, reduce the heat to “small flame” setting and allow the grill to heat up for 10/15 minutes.**

- ◆ Heating up- Always heat up the grill before starting to barbecue; use the ‘big flame’ setting.
- ◆ Heating up time- 6-10 minutes for food needing high temperatures;  
2-5 minutes for food needing low temperatures.
- ◆ Drip Tray – Before first use, the drip tray should be filled with sand to absorb fat and avoid the possibility of fat accumulating with the consequent risk of fire.
- ◆ First Aid – in the event of someone sustaining a burn, the affected part should be immediately plunged into cold water, or held under a running cold-water tap, for at least 5 minutes. Medical help and/or advice should be obtained as soon as possible.
- ◆ Do not leave the BBQ on the highest setting for an extended period – this may damage your BBQ.

### **6. Instructions for use**

- ◆ Leak control check – Before use, ensure the security of the Gas supply.
- ◆ To light –Open the lid of your grill before lighting. Do not stoop over the grilling space.

- ◆ Lighting instruction -
  - To ignite BBQ's with Piezo Ignition, turn the left hand burner control knob to the large flame symbol position (full rate) whilst pressing the piezo button several times.
  - If the burner does not light, turn the burner to the off position ( O ).
  - Wait 5 minutes and repeat the above lighting steps.
  - The remaining burners must be lit from the left hand side of the appliance in sequence to the right hand side of the appliance.
  - Never attempt to light a burner when the burner on its adjacent left hand side is not alight. ALWAYS LIGHT THE BURNERS IN SEQUENCE FROM LEFT HAND SIDE TO AVOID INCIDENT. IF POSSIBLE ALWAYS TURN OFF THE BURNERS IN THE SAME SEQUENCE AS PER IGNITION SEQUENCE SO THAT YOU ARE AWARE OF WHICH BURNERS ARE ALIGHT.
  - The same ignition sequence should also be followed in case of an ignition device failure. The barbecue should then be ignited with a match from the left hand side to the right.
  
- To ignite BBQ burners with battery operated ignition, turn the burner control knob to full open and push down on ignitor knob (red or black).
- Once all burners are lit preheat the cooking surfaces before cooking.

#### IMPORTANT:

- Should the flame be blown out by the wind, turn off the control knobs and wait five minutes before re-lighting.
- Keep children clear of the grill when in use, and after use until it is cold.
- Never move the grill while it is still hot.
- Should there be a smell of gas, turn off the gas immediately.

## 7. Cooking Tips

Before starting to cook, prepare everything in advance, and ensure that all food is properly cooked before it is consumed.

- ◆ Cut surplus fat off meat before grilling to avoid it dripping down causing flare-ups.
- ◆ Practice with cheap cuts in order to get to know your grill, before using expensive cuts.
- ◆ If desired, meat can be marinated (in oil, wine, herbs and spices). This improves taste and has a tenderizing effect. After marinating the meat must be dried before grilling as oily meat causes flare-ups and tends to burn.
- ◆ Herbs and spices should be used before the meat is placed on the grill.
- ◆ When grilling steaks grilling on high heat on both sides should seal the meat. Complete the cooking on lower temperature. Turning the steaks once.
- ◆ Use long tongs when grilling. Not a fork, as otherwise meat juices will be lost through pricking when turning meat over.

- ◆ Aluminium foil is most suitable for cooking vegetables, Wash the vegetables thoroughly but do not dry them. There will be sufficient water remaining to cook most vegetables. For very solid vegetables e.g. carrots, an ice cube can be packed into the foil. Close the foil well before placing the package on the grill.

## 8. Care and maintenance

- ◆ **Cooking Grates and Solid Plates-**
  - Ensure the lid is removed, and heat the grill for a few minutes on high heat.
  - Tune off the gas, take precautions against burns, and clean the grate surface with a metal brush. When cool, very dirty grates can be washed by hand.
  - Brush with cooking oil before use.
- ◆ **Flame Tamer Plate-**
  - Ensure that the lid is removed, and heat the grill for a few minutes on high heat.
  - Tune off the gas, take precautions against burns, and clean the grate surface with a metal brush. When cool, very dirty grates can be washed by hand.
- ◆ **Upkeep-**
  - Clean your barbecue after each USE. DO NOT use abrasive or flammable cleaners, as it will damage the parts of the product and may start a fire. Clean in warm soapy water.
  - CAUTION: All cleaning and maintenance should be carried out when the barbecue is cool and with the fuel supply turned OFF at the gas cylinder.
  - In order to maintain you grill in good condition and give you good service, it should be cleaned – depending upon the amount of use – once or twice a month as follows:
    - When cold, remove and clean the grates and flame tamer plate as described above.
    - Clean the inside of the grill body and front panel with detergents and rinse with clean water, then dry, before re-assembling.
    - Use a soft cloth or sponge to prevent scratches and marring of the steel surfaces.
    - Clean the trolley with any non abrasive metal polish.
    - Change the sand in the drip tray periodically
- ◆ **Cleaning burners-**
  - Cleaning of Gas parts must be carried out by a LPGSASA registered fitter, but the burners may be cleaned by following the instructions given hereunder.
  - When cold, having been removed, burners may be cleaned using a wire metal brush, the burner holes with a needle or similar, and the whole burner washed with water. Or blow clean with compressed air and wipe with a cloth.
  - Clean any clogged ports with a pipe cleaner or stiff wire (such as an opened paper clip).
  - Ensure that no water is retained in the burner, prior to re-

assembly.

- Inspect burner for any damage (cracks or holes). If damage is found, replace with a new burner. Reinstall the burner, check to ensure that the Gas valve orifices are correctly positioned and secured inside the burner inlet (venturi).

## **SERVICING**

Your gas barbecue should be serviced annually by a competent registered person.

### ◆ Storage-

- Turn off gas container valve, and remove regulator from container.
- Store gas container outside, on the ground level surface, upright, away from sunlight and any drains or gully, with valves closed and valve caps in place.
- Clean the grill as in 3 above
- When stored outdoors, the grill must stand on dry ground.
- Ensure a small amount of fat or cooking oil is on the cooking plates to prevent rust.
- While this appliance is not in use, it should be covered with the cover, to protect it from weather and other adverse conditions. In high humidity and/or ocean beach areas, make sure to keep the unit clean and polished. Use stainless steel cleaners, polishes or stainless steel oil protectants.

## **Warning**

**STORE CYLINDER IN A WELL VENTILATED AREA  
OUT OF REACH OF CHILDREN.**

When the gas cylinder is disconnected, replace the plug or cap on the valve outlet.

For extended storage it is suggested that the primary airports of the burners be covered against the penetration of insects or vermin.







Also a vinyl or canvas cover may be placed over the appliance.



**Do not allow food or liquid spills to accumulate in and on your BBQ**

## 9 . Troubleshooting-

<b>PROBLEM</b>	<b>CAUSE</b>	<b>CHECK</b>
Gas smell	<ol style="list-style-type: none"> <li>1. Orifice not fitted properly in the venturi tube</li> <li>2. Bent hose</li> </ol>	<ol style="list-style-type: none"> <li>1. Check the connection</li> <li>2. Straighten</li> </ol>
Burner does not light	<ol style="list-style-type: none"> <li>1. Gas tank is empty</li> <li>2. Gas supply turned off at the source</li> <li>3. Ignitor faulty</li> <li>4. Valve obstructed</li> </ol>	<ol style="list-style-type: none"> <li>1. Exchange for a new cylinder</li> <li>2. Turn on the gas supply</li> <li>3. Check ignitor spark</li> <li>4. Check valve inlet for obstructions</li> </ol>
Flame is low when burner control knob set at HIGH or flames do not run the whole length of burner	<ol style="list-style-type: none"> <li>1. Dirty burner</li> </ol>	<ol style="list-style-type: none"> <li>1. Clean burner holes with a small pin. Be careful not to enlarge holes</li> </ol>
Constant flare-ups	<ol style="list-style-type: none"> <li>1. Grill too cold before start of cooking</li> <li>2. Fatty foods</li> <li>3. Heat setting too high</li> </ol>	<ol style="list-style-type: none"> <li>1. Pre-heat the grill for 5-10 minutes</li> <li>2. Trim excessive fat from fatty meats</li> <li>3. Lower heat setting</li> </ol>
Burners light with a match but not with ignitor	<ol style="list-style-type: none"> <li>1. Gap between ignitor and ignitor point too big</li> <li>2. Loose or damaged wire connection</li> <li>3. Spark plug is dirty</li> <li>4. Battery too weak</li> </ol>	<ol style="list-style-type: none"> <li>1. Check gap – should be 2.5 -3mm</li> <li>2. Check all wire connections</li> <li>3. Check for excessive fat on sparker</li> <li>4. Unscrew ignitor cap and replace battery</li> </ol>

Instruction Manual Rev. 20 April 2008

	<p><b>IF YOU SMELL GAS:</b></p> <ol style="list-style-type: none"> <li>1. Shut off gas at the appliance, if possible</li> <li>2. Extinguish any open flame</li> <li>3. Open Hood</li> <li>4. If odour continues, call you gas expert.</li> </ol>
	<p>Do not store or use petrol or any other flammable vapours and liquids in the vicinity of this or any other appliance. This includes a gas cylinder not connected to the appliance.</p>
	<ul style="list-style-type: none"> <li>• Failure to comply with these instructions could result in a fire or explosion which could cause serious bodily harm, death or property damage.</li> <li>• Accessible parts may be very hot</li> <li>• Keep children away</li> <li>• Any modifications to this appliance could be very dangerous and will make your warranty null and void</li> <li>• Do not move the appliance while in operation</li> <li>• Please read the instruction very careful before using the appliance</li> <li>• After use, always turn the gas supply off at the source.</li> <li>• This appliance is for outdoor use only</li> </ul>
	<ul style="list-style-type: none"> <li>• Always use this appliance with a regulator for bottled gas</li> <li>• Keep the gas hose away from hot surfaces</li> <li>• Avoid unnecessary twisting of the hose</li> <li>• Always inspect the hose for damage before using the appliance</li> <li>• Never test for gas leaks with a flame.</li> <li>• Never light the BBQ with the lid or hood closed.</li> <li>• Never lean over the BBQ's cooking surface when igniting the BBQ</li> <li>• Always use good quality mittens when using your BBQ.</li> </ul>
	<p><b>Any of the following signs may indicate that your BBQ is not operating properly and may need servicing:</b></p> <ul style="list-style-type: none"> <li>• Excessive yellow flame</li> <li>• Irregular size of the flame across the length of the burner</li> <li>• Flame is Popping</li> <li>• Heavy Sooting</li> <li>• Abnormal noise</li> <li>• Hissing sound</li> </ul>
	<p>This appliance is not designed for the entire cooking surface to be covered with solid plates.</p>
	<ul style="list-style-type: none"> <li>• Fill the drip tray with a non-combustible absorbing material like sand, to avoid grease fires.</li> <li>• If a grease fire occur, attempt to close the gas supply at its source, turn off all burners and remove food if possible</li> <li>• Check all parts for damage after the grease fire is out and the BBQ is cool enough.</li> </ul>

	<ul style="list-style-type: none"><li>• At coastal areas frequent cleaning and maintaining is recommended to prolong the life of the appliance.</li><li>• Salty air will adversely affect the exposed parts.</li></ul>
	<p>Beware of spiders and insects</p> <ul style="list-style-type: none"><li>• Burners should be inspected and cleaned regularly.</li><li>• Spider nests and other insect nests like wasps could obstruct gas flow in the burners and venturi's.</li><li>• This could result in a flash back fire which can cause serious damage.</li><li>• Always visually check the burner flames to ensure proper flame pattern.</li></ul>